

Introducing converge[®]

The newest addition to Marley's OPTIM[®] range, Converge[®] is a unique PVC aerator ideal for single stack system applications.

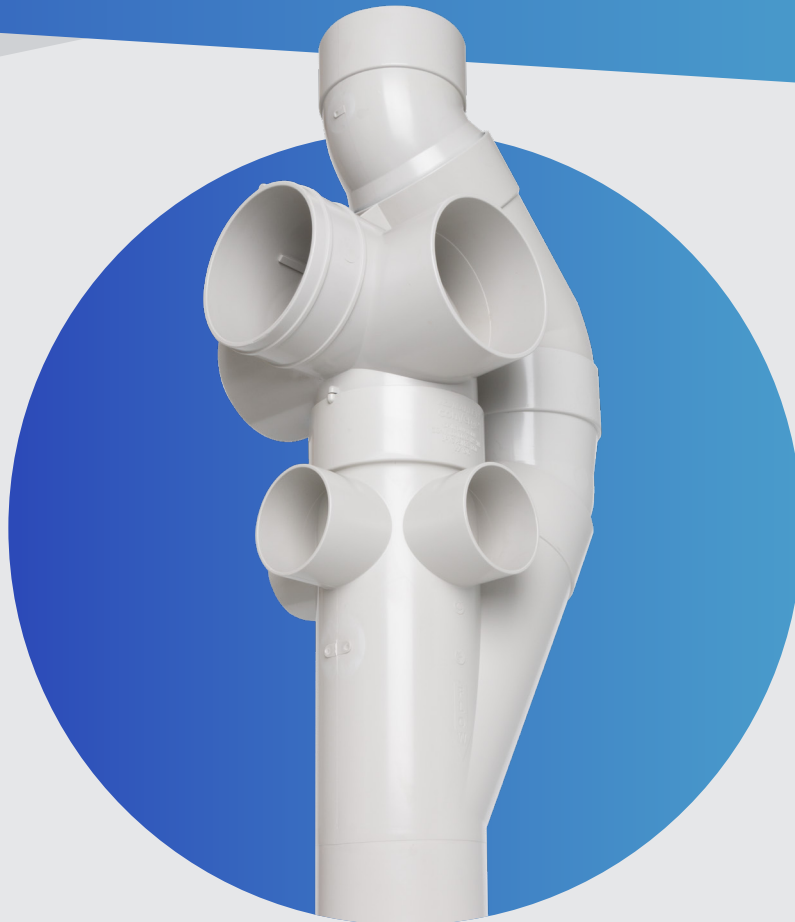
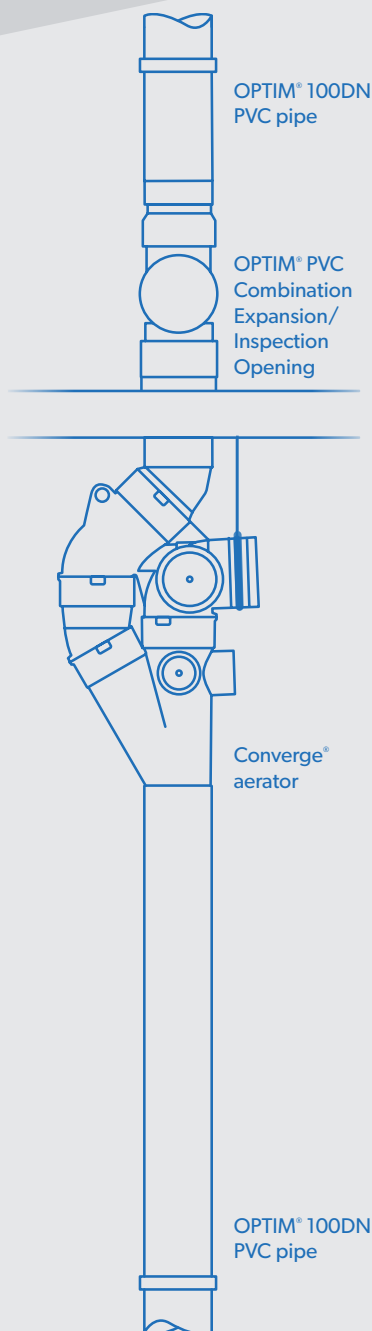

Save space

in service risers with integrated vent tube allowing more usable floor area



Less pipework

means less penetrations, less time, less cost



Seamless integration

with other OPTIM[®] PVC DWV pipes and fittings



Design flexibility

a single aerator fitting offers 6 branch connection options



WaterMark
WMKA1246



Recyclable
uPVC

OPTIM[®]

MARLEY[®]

by aliaxis

converge®

Designed specifically for multi-storey building designers and installers, Converge® is a single stack plumbing solution that saves space, materials, time and cost.

A traditional dual stack plumbing system has separate foul water and vent pipes. Converge® aerators allow for a single stack system which removes the need for the separate vent pipe. This gives building designers the flexibility to reduce the size of service ducts and create more usable floor space.

Converge® is made of PVC so installers benefit as it integrates seamlessly with Marley's tried and trusted OPTIM® DWV system. No extra on or offsite fabrication work is needed to adapt and fit the aerator. And as it's made of PVC it is AS/NZS 1260 compliant.

TRADITIONAL

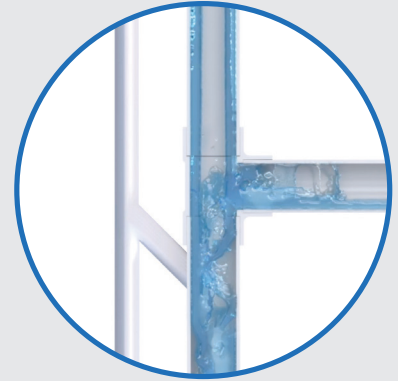

Dual stack

INNOVATIVE

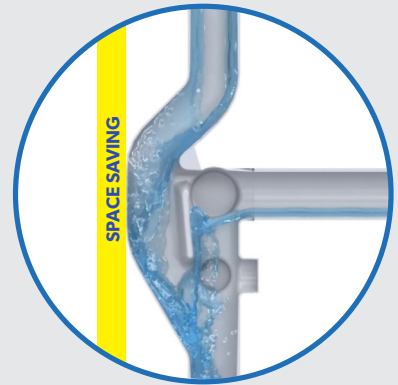

Single stack

Converge® PVC Aerator

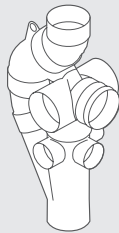

Expansion I/O

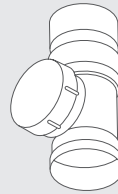

OPTIM® PVC Pipe

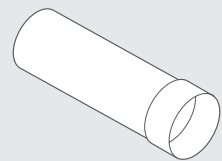

Product Code	CONV.100.PVC	111.100JL	100SN6.100.6
Description	Converge PVC Aerator 100DN	100 DWV Access Fitt & Expn	OPTIM SN6 Pipe 100DN 6M
Cartons per Pallet	26	N/A	N/A

0800 MARLEY (0800 627 539)
marley.co.nz

OPTIM®

MARLEY®
 by aliaxis