

dBLUE ACOUSTIC PLUMBING SYSTEM

SANITARY AND DRAINAGE

Technical Manual



THE SILENT TREATMENT

Vertical living and increased living standards have made acoustic comfort increasingly more important. It requires a solution beyond what has been traditionally available.

In this Specification Manual you will find the complete dBlue® Acoustic Soil & Waste product range. It is the latest addition to the Marley range of Specialist Drainage Systems.

The Marley dBlue® system is made from a state-of-the-art combination of plastic and sound absorbing mineral filler (PP-MD) to maximise absorbance of sound. It offers a unique combination of acoustic performance, weight, resistance and mechanical strength.

In addition to pipes, fittings, connection fittings, transition fittings and traps, you will find all required information on acoustic performance, planning and design, installation, bracketing and relevant standards and approvals.

dBlue® guarantees the proper functioning of your drainage system by combining training upfront, technical support during construction and (if required) inspection afterwards. The dBlue® system comes with a 10 year warranty, details are available on request. Special conditions apply.

This manual also comprises substantial technical details of the material properties and chemical resistance of the Marley dBlue® system. It will assist you with the application, design and installation.

For the best Silent treatment choose Marley dBlue®.



Applicability

This Specification Manual is applicable for Australia and New Zealand.

Validity

This Specification Manual 2015 is valid from July 2015. With the appearance of this manual previous manuals are no longer valid. The actual technical documentation can be downloaded at www.marley.co.nz.

This document is protected by copyright. The resulting rights, in particular those of translation, reprinting, reuse of illustrations, the radio broadcasting, reproduction by photo-mechanical or similar means, and storage in data processing systems, are reserved.

Important information and diagrams

This manual contains diagrams to emphasize important or beneficial information.

 Important information to take into account

 Consult the Marley dBlue® sales office

 Benefit

Disclaimer

Follow all applicable national and international assembly, installation, accident prevention, safety regulations and the information in this Specification Manual during the installation of drainage systems.

Also follow the applicable laws, standards, guidelines, regulations and instructions for environmental protection, professional associations and the local utility companies.

Applications not covered in this Specification Manual (special applications) require consultation with our technical department. For specific advice consult the Marley dBlue® sales office.

The planning and installation instructions are directly related to the respective Marley dBlue® products. The reference to standards or regulations is on a general level. Be aware of the current status of guidelines, standards and regulations. Other standards, regulations and guidelines regarding the planning, installation and operation of drainage or building systems need to be taken into account also and are not part of this Specification Manual.

Safety and operating instructions

- Read the safety and operating instructions completely for your own
- Read the safety and operating instructions completely for your own safety and the safety of others before the start of installation
- Store these instructions and keep them available
- If the safety instructions or installation instructions are unclear, please contact the Marley dBlue® sales office

General precautions

- Keep your work area clean and free of obstructing objects
- Provide adequate lighting of your work area
- Keep unauthorized persons away from tools and the work area, especially with renovations in inhabited areas
- Use only Marley dBlue® system components. The use of non-system components can lead to leakage or other problems
- If connecting to uPVC we recommend using the Marley Optim® uPVC system

During assembly

- Always read and follow the operating instructions
- Improper use of tools can cause severe cuts, bruising or dismemberment
- Improper use of tools can damage components and cause leaks
- Pipe cutters have a sharp blade. Store and handle without risk of injury
- Note the safety distance between your hand and cutting tool when cutting the pipes
- Never grip the cutting zone of the tool or moving parts during the cutting process

Health, Safety and Environmental

The use of the products referenced in this manual can expose the installer to a number of hazards due to standard work practices. These may include working at height, working in confined spaces, working in excavated trenches and working with wastewater and chemicals.

It is the responsibility of the installer to ensure that all legal requirements are met; particularly where licensed and/or authorised staff are required for plumbing and that the codes of practice of Workplace New Zealand are followed.

Information and safety recommendations	1
Table of contents.....	2
System information	4
1.1 Intended use	4
1.2 Applications	4
1.3 Triple-layer pipe.....	5
1.4 Uniform fittings	5
1.5 Acoustic brackets	5
1.6 Sound insulation.....	6
1.7 Packaging, transport and storage	6
1.8 Marking	7
1.9 Recycling	7
System and material properties	8
2.1 Technical specifications	8
2.2 Properties and benefits	9
2.3 Chemical resistance	10
Sound insulation	12
3.1 Noise in a soil & waste system.....	12
3.2 Sound insulation requirements.....	12
3.3 Sound reduction with Marley dBlue®.....	13
3.4 Acoustic testing.....	13
Planning and design	14
4.1 Relevant standards	14
4.2 Ceiling penetrations	14
4.3 Transition from downpipe to collector pipe.....	14
4.4 Horizontal change of direction	15
4.5 Transitions to other materials	15
4.6 Stormwater drainage and condensation	15
4.7 Professional kitchens	16
4.8 Fire protection.....	16
Fixing system	17
5.1 Bracketing plan in the vertical stack.....	17
5.2 Bracketing plan in horizontal pipes	18
5.3 Support bracing	18

Installation	19
6.1 Shortening and chamfering	19
6.2 Jointing pipes and fittings	20
6.3 Fixing system	20
6.4 Transitions to other materials	21
6.5 Floor waste gully.....	22
6.6 Shaft inspection.....	23
6.7 Embedding Marley dBlue® in concrete	23
6.8 Fire protection	23
6.9 Using pipe remainders without a socket	23
6.10 Additions to an existing system	23
Product range	24
7.1 Dimensions.....	24
7.2 Abbreviations	24
Pipes	
Pipe with socket	25
Fittings	
Reducer	25
Elbow	26
Branch.....	26
Clean out branch.....	27
Sleeve socket / Slip coupler.....	27
Double socket / Stop coupler.....	28
Socket plug	28
Trap connection socket	29
Trap connection bend	29
Traps	
Transition from PVC to dBlue®	30
Floor waste gully.....	30
Fixing material	
Acoustic bracket	31
dBlue® lubrication	31
Approvals, standards and quality	32
8.1 Approvals.....	32
8.2 Standards.....	32
8.3 Quality management.....	33
8.4 Warranty	33
8.5 Aliaxis	33

1 System information

1.1 Intended use

Marley dBlue® is an innovative noise-attenuated soil & waste drainage system, designed to be installed in accordance with AS/NZS 3500.2. It is suitable for use in multi-occupancy applications as well as hospitals and hotels and other commercial applications, where reduced noise levels are preferred.

Marley dBlue® is available in nominal diameters DN50 to DN160 with a full range of socketed pipes, a comprehensive range of fittings including brackets and transition adaptors.



The system has the following features:

- Complete rubber ring joint system with excellent sound-insulation properties
- A state-of-the-art combination of polypropylene and sound absorbing mineral filler (PP-MD) for air-borne noise reduction
- A triple layer pipe which is rigid, noise-attenuated with a smooth bore that resists incrustation and blockages
- Dedicated dBlue® brackets with rubber lining which dampen vibrations and reduce structure-borne noise
- Fast and easy installation without special equipment
- Robust fittings that resist on site and transit damage
- 100% recyclable



Illustration 1.1

1.2 Applications

Marley dBlue® is designed to be installed in accordance with AS/NZS 3500.2. Marley dBlue® meets the requirements of the Building Code for use in residential and commercial buildings.

Residential buildings

Excellent sound insulation properties result in a high noise reduction without lagging and is an effective alternative for insulated PVC in single and multi-occupancy buildings.

Commercial buildings

Marley dBlue® is an innovative and professional soil & waste drainage system and its many distinct features and high quality make it suited for a wide range of commercial applications like:

- Hotels, spas, luxury resorts
- Multi occupancy buildings
- High-rise buildings
- Multi-storey buildings
- Concert halls, museums and cinemas
- Hospitals
- Office buildings
- Professional kitchens

Application parameters

The pipes, fittings and seals can be used continuously at 90°C and up to 95°C for brief periods. They are suitable for the drainage of chemically aggressive waste water with a pH value of 2 (acidic) to 12 (basic).

Behaviour in fire corresponds to B2 normal combustibility according to DIN 4102 and E according to EN 13501-1.

Marley dBlue® is suited for installation down to -10°C.

For installations in applications not listed in this manual or with chemicals not listed in the Chemical Resistance list of this manual, please contact Marley for further advice.

Where not to use

Although Marley dBlue® is very versatile, it is not a true chemical drainage system and is not recommended for industrial chemical drainage and laboratory drainage.

The preferred solution for these applications is a homogenous welded PE or PP system using butt-welding and electrofusion technology like Marley HDPE. For HDPE systems, contact Marley.

1.3 Triple-layer pipe

The triple-layer pipe structure is produced using the latest co-extrusion technology. Each layer has its own function optimised to reduce sound levels, increase mechanical characteristics and improve the drainage flow.

The grey inner layer improves the drainage flow with a low friction smooth surface that is abrasion resistant and resistant to high temperatures. The middle layer is mineral filled and provides the pipe its excellent air borne noise absorption as well as a high pipe stiffness. The outer layer is impact resistant, has increased UV-resistance and allows installation down to -10°C.

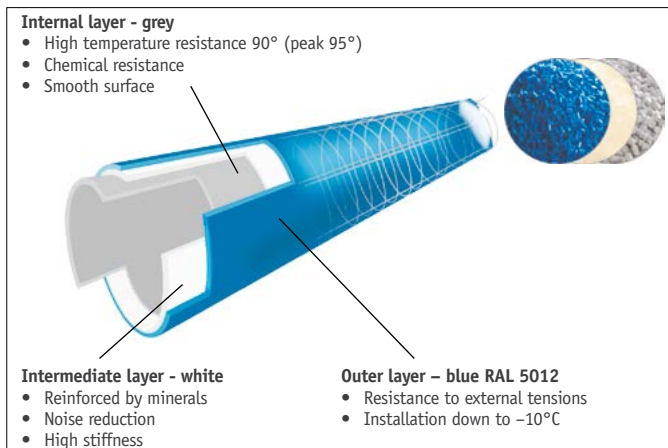

Illustration 1.2

Combined the three layers provide the dBlue® system with a pipe suited for a wide range of applications.

One end of each pipe has an integrated socket with rubber ring whilst the other side has a chamfered end which makes the pipe ready to install.

1.4 Uniform fittings

The dBlue® fittings have been designed for noise reduction and have many on-site benefits. All fittings are injection moulded (exceptions noted) from PP-MD in a uniform single layer. This provides the fittings with their excellent sound-insulation properties and a constant production quality. The fittings have a mat surface finish and the snap cap rubber ring containment make it a robust fitting.

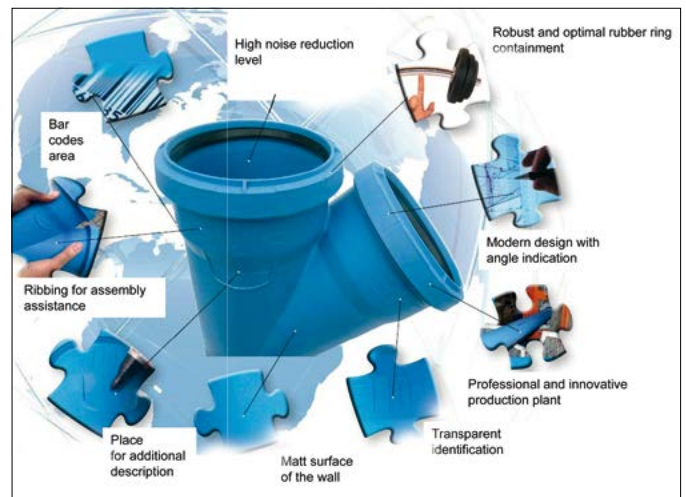

Illustration 1.3



Installation and inspection friendly

The snap cap contains an angle indication for correct positioning. The fitting body has a dedicated area where the installer can mark its position. The marking on the fitting is large and highly visible during inspection.

1.5 Acoustic brackets

dBlue® acoustic brackets support the system and contain a rubber lining to dampen the structure-borne noise vibrations.

The bracket is a single solution for both guide and anchor points in the installation. Use the provided spacers to create a guide bracket in open position. Without spacers the quick close mechanism fully tightens the bracket around the pipe to create a fixed point.

The bracket is installed with a M10 connection nut firmly welded to the bracket for easy connection to the building.

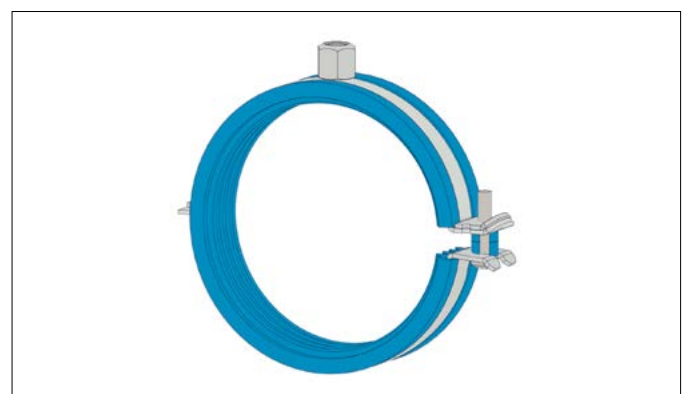

Illustration 1.4

1.6 Sound insulation

The dBlue® plumbing system has been tested as an international solution.

Australia and New Zealand share many plumbing standards. To offer the best proof of performance for a regional solution dBlue has been tested to Australian requirements for acoustic plumbing noise. These requirements include testing to established standards AS/NZS ISO 717.1:2004 and AS/NZS ISO 140.7:2006.

The Australian 'Deemed-to-Satisfy Provisions' for sound insulation rating of services are outlined in NCC/BCA Volume One Part F5 paragraph F5.6:

"F5.6 Sound insulation rating of services

If a duct, soil, waste or water supply pipe, including a duct or pipe that is located in a wall or floor cavity, serves or passes through more than one sole-occupancy unit, the duct or pipe must be separated from the rooms of any sole-occupancy unit by construction with an $R_w + C_v$ not less than:

- I 40 if the adjacent room is a habitable room (other than a kitchen); or*
- II 25 if the adjacent room is a kitchen or non-habitable room."*

R_w stands for a weighted sound reduction index and is a single-number quantity sound insulation rating. It basically indicates the effectiveness of a system as noise insulator. A higher number is a better performance.

C_v is a spectrum adaption term introduced to take into account a lower frequency range. C_v is always a negative number which will lower the weighted sound reduction index of R_w .

The index values are in decibels (dB) and A-weighted (dBA) in effort to account for the relative loudness perceived by the human ear, as the ear is less sensitive to low audio frequencies.

+ Marley dBlue® has been independently tested and meets the requirements without additional lagging.

1.7 Packaging, transport and storage

Packaging

Pipes up to 500 mm and fittings are packed in cardboard boxes. Where required, supplementary items in the cardboard boxes will be packed in a plastic bag.

Pipes longer than 500 mm are packed on wooden pallets and fastened with straps.

+ For optimal storage each pallet has additional support spacers (combs) installed to avoid shape deviation of the pipes. Two combs are installed for pipe lengths between 1 and 2 m, and three combs for 3 m long pipes.

The pipes are packed socket end next to spigot end for the proper shape retention.

Transport

Pipes and fittings still packed in their original packaging (cardboard box or pallet) must be secured against movement and deflection.

Individual lengths of pipe transported loose should be transported 'side by side': socket end next to spigot end for proper shape retention. The pipes must be firmly supported over the entire length and secured from movement and defect.

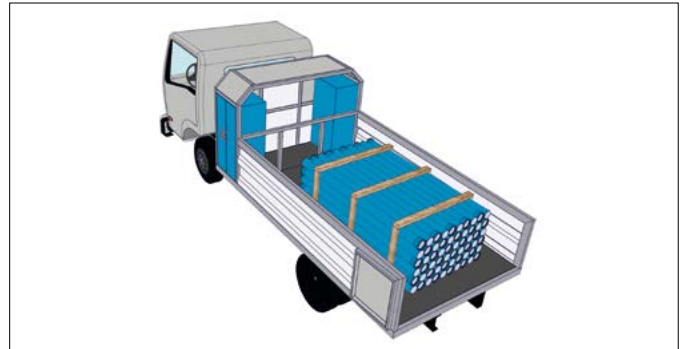

Illustration 1.5

During the transport of pipes and fittings exposure to rain and snow should be limited.

Storage

Pipes should be stored in their original lengths in stacks on a flat and clean area. Ensure that the wooden frames are aligned squarely when stacking. The first level of the stack should always be laying on the wooden blocks of the pallets.

The maximum safe height of the stack shouldn't exceed 2,5 m.

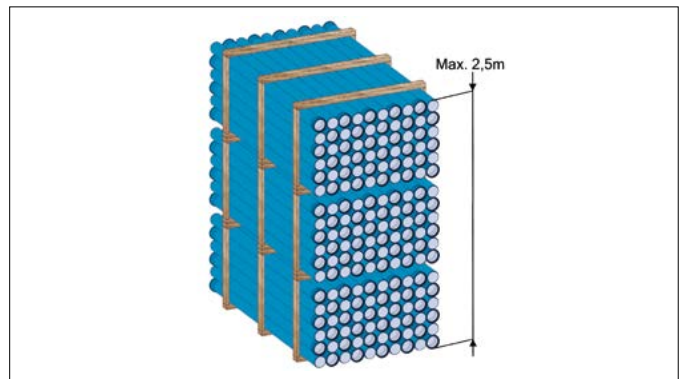

Illustration 1.6

Outside storage of pipe crates is possible when the following guidelines are followed:

- Pipes are protected from direct sunlight (with proper ventilation)
- Storage up to 12 months is possible when the pipes are kept packaged in the original UV resistance stretch foil
- Storage up to 6 months is possible when the pipes are not protected by the original UV resistance stretch film
- Storage temperature should not exceed 60°C

Pipes which have been exposed to UV radiation over a longer period of time can fade in colour. It has no negative effect on the pipe's structure and mechanical resistance.

Store pipes in such a manner that no objects are placed on top of the sockets and spigot ends to ensure that these are not deformed.

Fittings should be kept in their original packaging in a dry covered area and be protected against moisture, dirt, solids and UV radiation.

+ Any product over 25 kilos needs to be lifted mechanically.

1.8 Marking

dBlue® pipes and fittings are marked with:

- Manufacturer's mark or brand
- Material type
- Nominal diameter
- Area of application
- Conformity of dimensions
- Resistance to low temperatures
- Fire resistance class
- Approvals information
- Information on recycling
- Production year

- Production month and day (pipe only)
- Wall thickness (pipe only)
- Time, shift number and production line number (pipe only)

- EAN barcode (fittings only)
- Angle indication (fittings only)

1.9 Recycling

dBlue® pipes and fittings are 100% recyclable.

Left over dBlue® materials should be recycled as following:

Remainder pipe	: residual waste
Remainder fittings	: residual waste
Lubrication	: residual waste
Cleaning cloths	: residual waste
Wooden crating	: recycled wood
Plastic spacers	: residual waste
Carton boxes	: recycled paper



Illustration 1.7

2 System and material properties

The Marley dBlue® system is made from a state-of-the-art combination of plastic and sound absorbing mineral filler (PP-MD). The material formula is developed by the Aliaxis R&D laboratory and offers a unique combination of acoustic performance, weight, resistance and mechanical strength. The triple-layer pipe structure is produced using latest co-extrusion technology. Each layer has its own function optimised to reduce sound levels, increase mechanical characteristics and improve the drainage flow.

2.1 Technical specifications

Property	Value
Material	PP-MD mineral-reinforced (pipes and fittings)
Size range	DN40 to DN160
Wall thickness	DN40-50 -> 1,8 mm, DN75 -> 2,3 mm DN90 -> 2,8 mm, DN110 -> 3,4 mm DN125 -> 3,9 mm, DN160 -> 4,9 mm
Area of application	Drainage pipes in buildings and above ground installation
Chemical resistance	Polypropylene basis No waste water containing benzene Seals made of SBR
Application	Waste water with pH value 2 - 12 Waste water temperature up to 90°C (continuous load) and 95°C for brief periods
Density	External layer: 1,2 g/cm ³ Internal layer: 1,4 g/cm ³
Coefficient of thermal expansion	0,10 mm/mK
Ring stiffness	> 4 kN/m ²
Colour	Internal layer: light grey (RAL7040) Middle layer: cream white (natural without any dye) External layer: blue (RAL5012)
Structure	Triple-layer pipe Uniform fitting
Connection	Rubber ring joint socket with factory-installed lip sealing ring
Fire behaviour	B2 (normally inflammable) DIN 4102-1 E (normally inflammable) EN 13501-1
System compatibility	Adaptors from PVC system and copper are available
Standards and approvals	System tested according to AS/NZS 7671 WaterMark WMK25729
Sound insulation	Fullfills BCA/NCC requirement of $R_w + C_{tr}$ 40 for habitable rooms Tested to ISO 140 methodology. Sound insulation performance rated according to ISO 717
Independent monitoring	Süddeutsches Kunststoffzentrum (SKZ), Germany

Table 2.1

2.2 Properties and benefits

	Properties dBlue®	Benefits
	Combined plastics and minerals	High degree of noise reduction
	Impact-resistant and tough	Unbreakable temperatures > 5°C
	Thermal resistant	Application possible between -10°C and 95°C
	Smooth internal wall	Low blockage risk due to low deposit/residue effects
	Wear resistant	Lower costs due to relatively long life
	Chemical resistant	Suitable for transport of polluted waste water
	Poor heat conductivity	No condensation during short periods of cooling
	Recyclable	Environmentally friendly
	Insulating	Non-conductive
	Light in weight	Cost-saving in transport and handling

Table 2.2

2.3 Chemical resistance

The current state of knowledge about chemical resistance of plastics is based on long-lasting laboratory tests and practical experience. The following evaluation can be an initial indicator of the possibilities of Marley dBlue® application for fluid transportation including transport at elevated temperatures. dBlue® pipes and fittings and rubber gaskets are meant for transporting waste water ranging from acids (pH 2) to alkalis (pH 12) present in households. In case of industrial waste water, its chemical composition and concentration should be analyzed. The table covers a set of chemicals and determination of Marley dBlue® chemical resistance. The following evaluation criteria were adopted:

Used symbols:

- + Resistant: in general Marley dBlue® is a suitable material for this application
- / Limited resistance: further research necessary
- No resistance

Empty field No data available

Abbreviations:

- Sat. sol Saturated aqueous solution: prepared at 20°C
- Sol Aqueous solution at a concentration higher than 10% but not saturated

Component	Concentration	Temperature		
		20°C	60°C	100°C
Acetic acid	Up to 40%	+	+	
Acetic acid	50%	+	+	/
Acetic acid, glacial	>96%	+	/	-
Acetic anhydride	100%	+		
Acetone	100%	+	+	
Acrylonitrile	100%	+		
Allyl alcohol	100%	+	+	
Ammonia, aqueous	Sat. sol	+	+	
Ammonia, dry gas	100%	+		
Ammonia, liquid	100%	+		
Ammonium acetate	Sat. sol	+	+	
Ammonium chloride	Sat. sol	+	+	
Ammonium nitrate	Sat. sol	+	+	+
Ammonium sulphate	Sat. sol	+	+	+
Aniline	100%	+	+	
Beer		+	+	
Benzene	100%	/	-	-
Benzoic acid	Sat. sol	+	+	
Borax	Sol	+	+	
Boric acid	Sat. sol	+		
Bromine, liquid	100%	-	-	-
Butane, gas	100%	+		
Butanol	100%	+	/	/
Butyl acetate	100%	/	-	-
Calcium carbonate	Sat. sol	+	+	+
Calcium nitrate	Sat. sol	+	+	
Carbon dioxide, dry gas		+	+	
Chlorine, dry gas	100%	-	-	-
Chlorine, liquid	100%	-	-	-
Chloroform	100%	/	-	-
Chlorosulphonic acid	100%	-	-	-
Chromic acid	Up to 40%	+	/	-
Citric acid	Sat. sol	+	+	+
Copper (II) chloride	Sat. sol	+	+	
Cyclohexanone	100%	/	-	-

Component	Concentration	Temperature		
		20°C	60°C	100°C
Dextrin	Sol	+	+	
Dichloroethylene (A and B)	100%	/		
Dichloromethane	100%	/	-	
Ethanolamine	100%	+		
Ethyl alcohol	Up to 95%	+	+	+
Ethyl ether	100%	+	/	
Ethylene glycol	100%	+	+	+
Formaldehyde	40%	+		
Formic acid	10%	+	+	/
Gasoline, petrol (aliphatic hydrocarbons)		-	-	-
Glycerine	100%	+	+	+
Glycolic acid	30%	+		
Hexane	100%	+	/	
Hydrochloric acid	Up to 20%	+	+	+
Hydrochloric acid	30%	+	/	/
Hydrogen peroxide	Up to 30%	+	/	
Hydrogen sulphide, dry gas	100%	+	+	
Lactic acid	Up to 90%	+	+	
Magnesium chloride	Sat. sol	+	+	
Magnesium sulphate	Sat. sol	+	+	
Milk		+	+	+
Monochloroacetic acid	>85%	+	+	
Nitric acid	Up to 30%	+	-	-
Nitric acid	From 40 to 50%	/	-	-
Oleic acid	100%	+	/	
Oleum (sulphuric acid with 60% of +03)		+	/	
Oxalic acid	Sat. sol	+	/	-
Oxygen, gas		+		
Phenol	90%	+		
Potassium bromate	Up to 10%	+	+	
Potassium chlorate	Sat. sol	+	+	
Potassium chromate	Sat. sol	+	+	
Potassium cyanide	Sol	+		
Potassium dichromate	Sat. sol	+	+	+
Potassium ferricyanide	Sat. sol	+	+	
Potassium hydroxide	Up to 50%	+	+	+
Potassium nitrate	Sat. sol	+	+	
Potassium permanganate	(2 N) 30%	+		
Propane, gas	100%	+		
Pyridine	100%	/		
Seawater		+	+	+
Sodium chlorate	Sat. sol	+	+	
Sodium hydroxide	From 10 to 60%	+	+	+
Sodium hypochlorite	From 10 to 15%	+		
Sodium sulphite	40%	+	+	+
Sulphuric acid	Up to 10%	+	+	+
Sulphuric dioxide, dry or wet	100%	+	+	
Tartaric acid	Sat. sol	+	+	
Tin (IV) chloride	Sol	+	+	
Tin (II) chloride	Sat. sol	+	+	
Toluene	100%	/	-	-
Trichloroethylene	100%	-	-	-
Urea	Sat. sol	+	+	
Vinegar		+	+	
Wines		+	+	
Xylene	100%	-	-	-

Table 2.3

3 Sound insulation

3.1 Noise in a soil & waste system

Noise is all around us all the time. In modern urbanised life there are few places left to enjoy the comfort of silence. In many building constructions like multi-storey apartment blocks, hospitals or luxurious spas, the sound of the sanitary and drainage systems have become a significant source of noise. Modern standards require the noise to stay within acceptable limits for everyday use.

Every object in motion makes noise transmitting its vibrations to the surrounding air as pressure waves. There are two types of noise in soil & waste systems:

Air-borne noise

This is sound that travels through the air from its source. The source causes the air to vibrate. Air-borne noise can pass through structures and is reduced by using absorbent materials.

Structure-borne noise

This is sound that first occurs through a solid structure generated from a vibrating source or impact event. The vibrations pass through the structure and reach the human ear as air-borne noise at different locations within the building. The building structure acts as an acoustic bridge. Structure-borne noise is reduced by using soft material to acoustically uncouple the vibrating source or impact event.

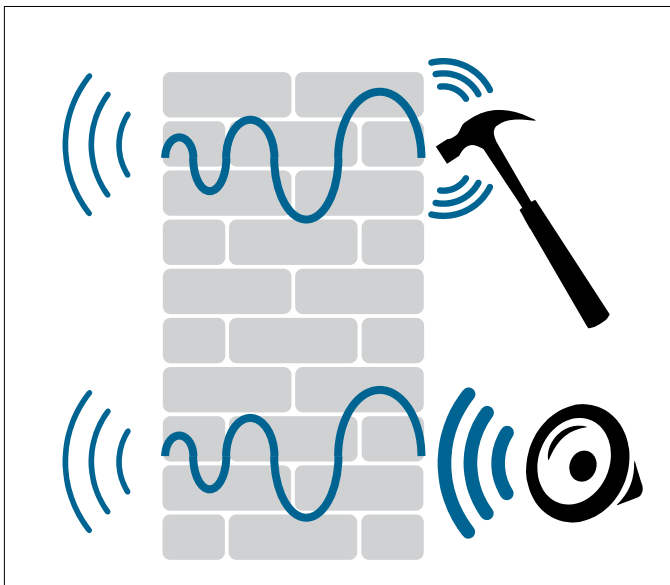

Illustration 3.1

3.2 Sound insulation requirements

The dBlue® plumbing system has been tested as an international solution.

Australia and New Zealand share many plumbing standards. To offer the best proof of performance for a regional solution dBlue has been tested to Australian requirements for acoustic plumbing noise. These requirements include testing to established standards AS/NZS ISO 717.1:2004 and AS/NZS ISO 140.7:2006.

The Australian 'Deemed-to-Satisfy Provisions' for sound insulation rating of services are outlined in NCC/BCA Volume One Part F5 paragraph F5.6:

"F5.6 Sound insulation rating of services

If a duct, soil, waste or water supply pipe, including a duct or pipe that is located in a wall or floor cavity, serves or passes through more than one sole-occupancy unit, the duct or pipe must be separated from the rooms of any sole-occupancy unit by construction with an $R_w + C_{tr}$ not less than:

- I 40 if the adjacent room is a habitable room (other than a kitchen); or*
- II 25 if the adjacent room is a kitchen or non-habitable room."*

R_w stands for a weighted sound reduction index and is a single-number quantity sound insulation rating. It basically indicates the effectiveness of a system as noise insulator. A higher number is a better performance.

C_{tr} is a spectrum adaption term introduced to take into account a lower frequency range. C_{tr} is always a negative number which will lower the weighted sound reduction index of R_w .

The index values are in decibels (dB) and A-weighted (dBA) in effort to account for the relative loudness perceived by the human ear, as the ear is less sensitive to low audio frequencies.

3.3 Sound reduction with Marley dBlue®

Noise in a soil & waste system is caused by waste water flowing inside a drainage pipe system. The waste water is turbulent and causes noise as well as vibrations in the pipe structure.

The vibrations are emitted directly from the pipe surface as air-borne noise and as structure-borne noise to the wall through the fixing system. Marley dBlue® has been designed to reduce both air-borne and structure-borne noise.

How Marley dBlue® reduces air-borne noise

Air-borne noise is reduced using absorbent materials. The plastic PP-MD used for Marley dBlue® is a special formula adding sound-dampening mineral fillers with increased weight to maximise the absorbance of air-borne sound waves. The triple layer pipe and rubber ring joints further reduce acoustic vibration in the system.

How Marley dBlue® reduces structure-borne noise

Structure-borne noise is reduced by using soft material to acoustically uncouple the vibrating source or impact event. The dBlue® acoustic bracket has a special rubber lining designed to best uncouple any vibrations from the pipe system.

The combination of all these features is what makes Marley dBlue® a system that takes reduction of soil & waste noise to the next level.

Non-system specific installation practice will also benefit a lower noise level, like to install the pipe systems to the heaviest wall and to properly insulate a pipe section passing through building slabs and other structural barriers.

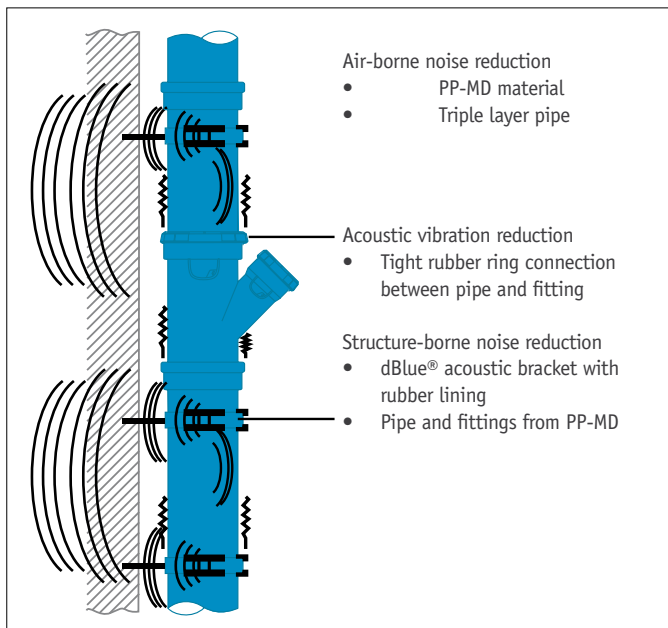

Illustration 3.2

- ⊕ No acoustic lagging required
- Marley dBlue® does not require additional acoustic lagging, offering many significant advantages:
 - No lagging material required
 - No lagging installation time
 - Less scheduling of companies
 - Consistent acoustic results during installation lifetime
 - No unverified lagging materials
 - Faster and easier inspection
 - Faster and easier maintenance

3.4 Acoustic testing

Marley dBlue® has been independently tested by the Commonwealth Scientific and Industrial Research Organisation (CSIRO) and meets the Australian $R_w + C_{tr}$ 25 and 40 benchmarks without the need for lagging.

CSIRO is Australia's national science agency, and is one of the largest and most diverse scientific institutions in the world with more than 50 sites throughout Australia and overseas.

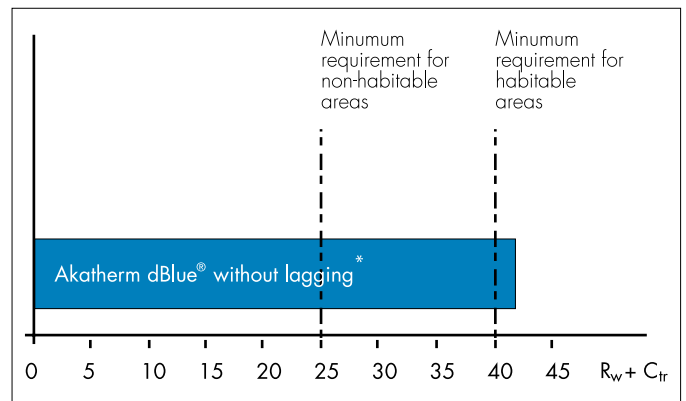

Illustration 3.3

* $R_w + C_{tr}$ 40 results are extrapolated based on the $R_w + C_{tr}$ 25 results. Comparative testing with uPVC and lagging based on using 13mm Plasterboard and R1.5 insulation batts.

Note. dBlue is not intended for exposed installations. To meet acoustic requirements in habitable areas, the system must be separated from the living space by an industry standard ceiling or wall structure.

A dBlue system reduces structure-borne noise by using a proprietary clip system to isolate the pipe from the building structure.

Two 45° bends at changes in direction are recommended instead of a single 88° bend as this will lessen turbulence and as such, generate less noise.

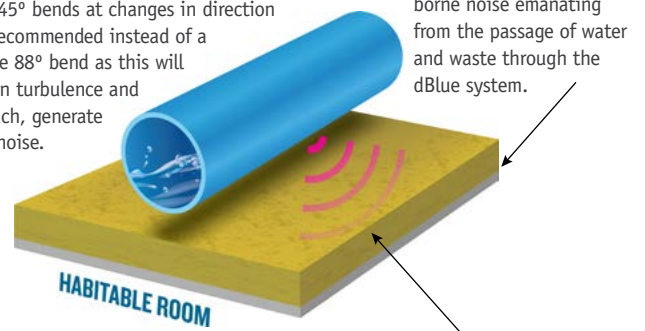

The construction materials between dBlue pipe and adjacent room must have a sound reduction level of $R_w + C_{tr} \geq 40$ for a habitable room or $R_w + C_{tr} \geq 25$ for a non-habitable room or kitchen.

4 Planning and design

4.1 Relevant standards

dBlue has Certification to Australian and New Zealand Standards

dBlue is designed in accordance with the installation standard AS/NZS3500.2. The system complies with AS/NZS 7671 and has WaterMark certification. The dBlue system has been developed under a ISO 9001 Quality management system and ISO 14001 Environmental management system.

- **AS/NZS 7671:2010** – Plastic piping systems for soil and waste discharge (low and high temperature) inside buildings – Polypropylene (PP)
WaterMark - WMK25729
- **AS/NZS 5065:2005** – Polyethylene and polypropylene pipes and fittings for drainage and sewerage applications
WaterMark – WMK25751
- **Branz appraisal - No 610**



Acoustic performance

Acoustic performance shall meet the requirements as described in the Australian 'Deemed-to-Satisfy Provisions' for sound insulation rating of services is outlined in NCC/BCA Volume One Part F5 paragraph F5.6:

"F5.6 Sound insulation rating of services

If a duct, soil, waste or water supply pipe, including a duct or pipe that is located in a wall or floor cavity, serves or passes through more than one sole-occupancy unit, the duct or pipe must be separated from the rooms of any sole-occupancy unit by construction with an $R_w + C_{tr}$ not less than:

- I. 40 if the adjacent room is a habitable room (other than a kitchen); or
- II. 25 if the adjacent room is a kitchen or non-habitable room."

$R_w + C_{tr}$ shall have the required value rated in accordance to ISO 717 measured according to ISO 140.

Fire rating

Marley dBlue® has fire behaviour class B2 (normally inflammable) according to DIN 4102-1 and class E (normally inflammable) according to EN 13501-1. When Marley dBlue® passes through fire-rated building elements it is mandatory to install fire protection collars that will not reduce the fire-rating of these building elements.

The Marley dBlue® system dimensions can be installed in combination with a range of fire protection collars. The installed system needs to be in accordance with AS 1530.4. Details available upon request.

4.2 Ceiling penetrations

Each duct in a construction barrier must be constructed with a sleeve made of material that ensures acoustic insulation and prevents against moisture. Proper acoustic insulation will prevent an acoustic bridge through contact noise.

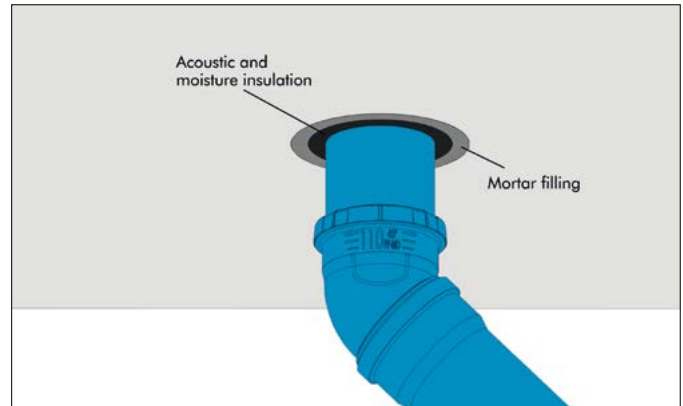

Illustration 4.1

Appropriate protective measures need to be taken when the pipe system can come into contact with hot floor coverings like mastic asphalt.



Fire-protection may be required when the pipe system passes through fire-rated building elements.

4.3 Transition from downpipe to collector pipe

At the bottom of the vertical stack the waste water will be at its highest volume and speed. At this point the transition to horizontal must be designed using 2 x 45° fittings with a 250 mm dBlue® pipe in between. This will prevent unwanted pressure spikes by allowing air to move freely in the pipe system. Furthermore a gradual transition will decrease the noise level.

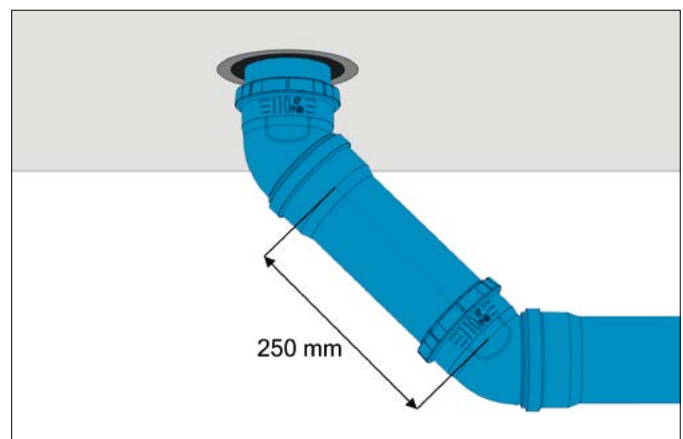

Illustration 4.2

dBlue® acoustic brackets should be installed behind each socket to maximise fixation at the bottom of the stack and absorbing vibrational energy (=noise). To minimise the distance from the collector pipe to the ceiling the top elbow can be embedded in the ceiling.

4.4 Horizontal change of direction

Ensure gradual horizontal transitions are made using two 45° elbows (or swept bend) to decrease noise levels compared to the use of a 90° elbow.

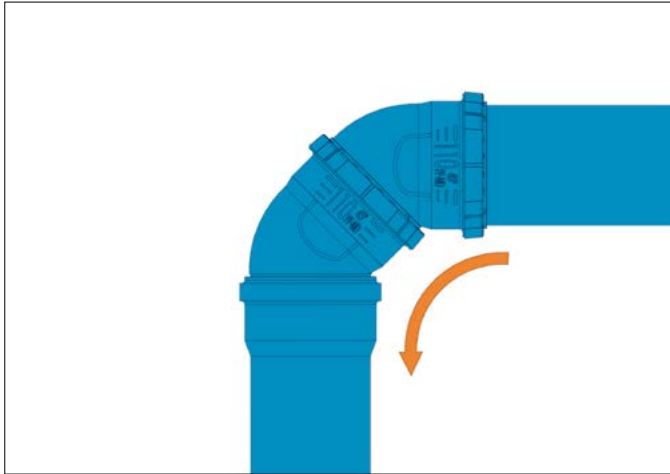

Illustration 4.3

4.5 Transitions to other materials

4.5.1 PVC system

PVC systems are manufactured according to AS/NZS 1260 and have different pipe sizes from Marley dBlue® below DN110. Refer to the table below for PVC and dBlue® pipe sizes.

PVC		Marley dBlue®	
DN	OD (mm)	DN	OD (mm)
40	43	40	40
50	56	50	50
65	69	75	75

Table 4.1

Connections to and from PVC systems with non-compatible diameters are possible using PVC adaptor fittings from the Marley dBlue® range. The adaptor fitting can be connected to the PVC system using solvent cement and inserted into a dBlue® socket using lubricant.

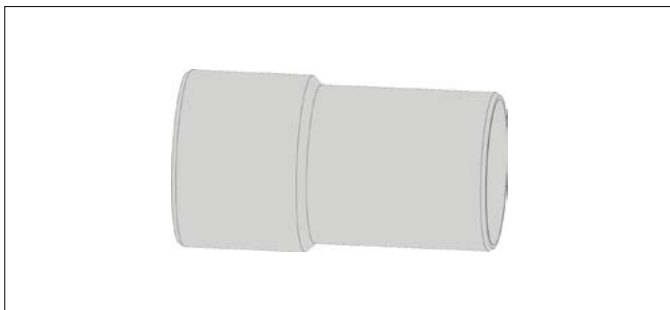

Illustration 4.4

For pipe sizes d110 mm and 160 mm no adaptor fitting is required since both systems have identical outer diameters. The PVC pipe can simply be inserted into the dBlue® socket using lubricant.

One transition requires the use of an additional dBlue® eccentric reducer.

From PVC DN	To dBlue® DN	PVC adaptor OD (mm)	Reducer OD (mm)
40	50	43/40	
50	50	56/50	
65	75	69/75	

Table 4.2

The connection from Marley dBlue® DN50 to PVC DN50 can be made using the PVC adaptor 56/50 in combination with dBlue® double socket 50 mm.

4.5.2 Cast iron and other materials

For connections from and to cast iron or other drainage pipe materials it's advised to use flexible rubber sleeve adaptors with stainless steel worm-gear clamps.

The rubber sleeve adaptor should have the same temperature and chemical resistance as the Marley dBlue® system.

Check the rubber sleeve manufactures guidelines for correct installation and material specifications.

4.6 Stormwater drainage and condensation

When using Marley dBlue® for stormwater drainage the relatively cold rainwater can cause dew condensation on the outside pipe surface within the building.

Condensation occurs when the water vapour carried in the air is deposited on a 'colder' surface. Air at a given temperature can contain only a certain amount of water vapour. If the air temperature drops when in contact with the colder pipe system, the excess amount of water vapour will then condense.

The temperature of the air at which air is saturated with water vapour is called the 'dew point'. Condensation occurs when pipework has a temperature under the dew point of the surrounding air. Condensation depends on a number of factors:

- Room temperature
- Relative humidity of the air
- Temperature of the pipe surface

Marley dBlue® has a relatively good thermal coefficient and no condensation will occur during short periods of rain. To know exactly when and how to insulate a h-x (Mollier) diagram and a detailed calculation has to be used.

When insulating the pipe system use diffusion-proof closed cell insulation material. Open cell insulation has to have an impermeable outer layer.

The entire pipe network must be insulated and an insulated pipe system must always be a closed circuit. Always ensure to:

- Close all openings, cuts and transitions with sealing material
- Encase the bracket fully and seal the transition

4.7 Professional kitchens

Animal and vegetable-based oil and grease discharged by commercial kitchens are separated from the waste water by grease separators. Marley dBlue® is very well suited to connect the discharge fixtures to the grease separator. When the pipe system has enough length, the grease can accumulate and lead to serious blockage of the pipe system.

The use of trace heating and additional insulation may be required to reduce heat loss. The trace heating element should not exceed 45°C.

4.8 Fire protection

Marley dBlue® has fire behaviour class B2 (normally inflammable) according to DIN 4102-1 and class E (normally inflammable) according to EN 13501-1. When Marley dBlue® passes through fire-rated building elements it is mandatory to install fire protection collars that will not reduce the fire-rating of these building elements.

The Marley dBlue® system dimensions can be installed in combination with a range of fire protection collars. The installed system needs to be in accordance with AS 1530.4. Details are available upon request.

We advise to follow the manufacturer's guidelines with respect to design, installation, commissioning and maintenance of the used fire protection collars. Contact the responsible authority for compliance with applicable regulations.



During design, installation and commissioning of the fire protection collars the applicable on-site, local and national regulations must be observed.

5 Fixing system

Marley dBlue® is a complete system including dBlue® acoustic brackets for optimal sound dampening. The dBlue® fixing system includes:

- Vertical bracketing plan
- Horizontal bracketing plan
- Correct use of guide and anchor point brackets
- Correct tension free installation of each bracket
- Correct installation of each dBlue® joint
- Support bracing

Using dBlue® acoustic brackets and following the guidelines in this manual will ensure that the Marley dBlue® soil & waste system will be supported correctly over time and allow for temperature changes while achieving the desired sound reduction level.

All dBlue® brackets have a M10 nut for connection to the wall and ceiling.

Guide and anchor point bracket

The Marley dBlue® fixing plan requires the use of guide and anchor point brackets. The dBlue® acoustic bracket is designed to function as a guide bracket in the open position by using two spacers at the bracket closing point. Without the spacers the bracket fully closes and can be used as an anchor point bracket.

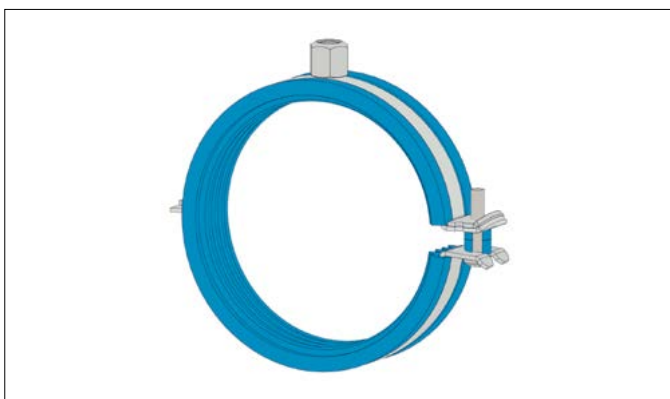

Illustration 5.1

Thermal expansion and contraction

Marley dBlue® is a rubber ring joint system that takes up thermal expansion and contraction of the pipe system in each joint. This is only possible when following the dBlue® joint installation instructions (pulling back the pipe 10 mm after full insertion in the socket). The 10 mm additional room in the joint is sufficient to take up at least 30°C difference between installation and operational temperature.

- ! Pipes longer than 500 mm have to be pulled back 10 mm after full insertion in the socket to allow thermal expansion of the pipe system.

5.1 Bracketing plan in the vertical stack

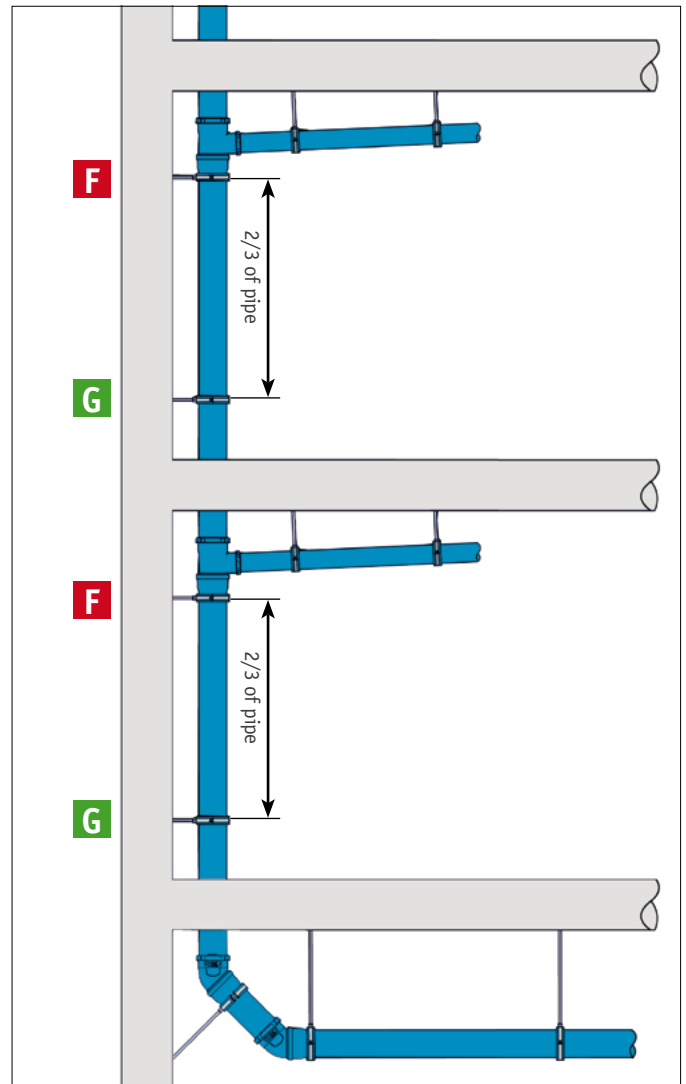

Illustration 5.2

- F** Anchor point bracket (closed without spacers)
- G** Guide bracket (open with 2 spacers)

One fitting per floor level

- Fixed point bracket directly below each socket
- Guide bracket at $\frac{2}{3}$ of the pipe length

More than one fitting per floor level

- Secure each socket with an anchor point bracket
- Place a guide bracket when the pipe length between the anchor point brackets is more than 20x the pipe diameter

Install an anchor point bracket behind each socket at the bottom of the stack where the downpipe transitions to the collector pipe.

The anchor point bracket fixes the socket so that the thermal expansion can be accommodated. The guide bracket keeps the pipe in a straight line to the next socket.

- ! Expansion forces will be transmitted to the brackets. Make sure to follow instructions in this manual on support bracing in order to keep all brackets in their original place of installation.

5.2 Bracketing plan in horizontal pipes

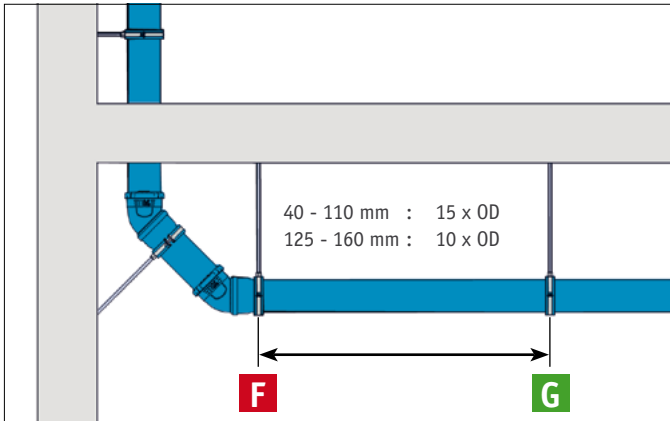

Illustration 5.3

- F** Anchor point bracket (closed without spacers)
- G** Guide bracket (open with 2 spacers)

Anchor point brackets

- Always place an anchor point bracket directly behind each socket.

Guide brackets

Horizontal pipe lengths between the anchor points must be supported by guide brackets at regular intervals:

- 40 - 110 mm : 15 x pipe diameter
- 125 - 160 mm : 10 x pipe diameter

When the pipe system layout does not allow specified guide brackets intervals, decrease interval length until possible.

The anchor point bracket fixes the socket in which the thermal expansion can be accommodated. The guide brackets support the pipe to avoid sagging.

! Expansion forces will be transmitted to the brackets. Make sure to follow instructions on support bracing in order to keep all bracket in their original place of installation.

5.3 Support bracing

The support bracing used for the dBlue® fixing system should be designed to withstand:

- The fully filled weight of the pipe system (W)
- The transmitted expansion forces (E) over the full support length (L)

Pipe system weight

The weight of the pipe system (W) is according to the table below.

Pipe diameter	Empty weight	100% filled weight
DN	(kg/m)	W (kg/m)
50	1,3	3,0
75	1,7	6,0
110	2,5	11,0
160	5,0	23,0

Table 5.1

Transmitted expansion forces

Marley dBlue® takes up thermal expansion and contraction of the pipe system in each joint. The friction between the rubber ring and the pipe is the resistance

force (E) that will be fully transmitted to the threaded rod with length L.

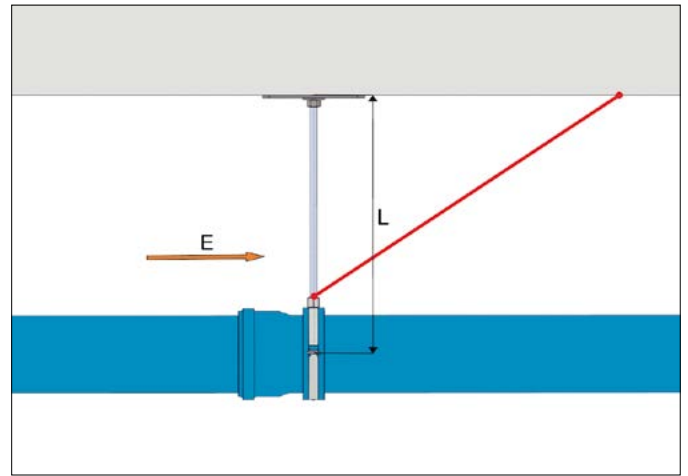

Illustration 5.4

The table below shows the socket resistance force E.

Pipe diameter	Force E	
DN	(N)	(kg)
50	200	20
75	250	25
110	400	40
160	800	80

Table 5.2

Because the thermal expansion is compensated for the sockets it is very important to install the pipes correctly into the sockets.

! Pipes longer than 500 mm have to be pulled back 10 mm after full insertion in the socket to allow thermal expansion of the pipe system.

The 10 mm additional room in the joint is sufficient to take up at least 40°C difference between installation and operational temperature.

Thermal expansion over 40°C will put additional force on the bracing system and will possibly require stronger bracing.

☎ Contact your local dBlue® distributor for advice when the difference between installation and continuous operational temperature exceeds 40°C.

6 Installation

6.1 Shortening and chamfering

dBlue® pipes and fittings have factory made sockets and chamfered spigot ends. Pipe is available in several standard pipe lengths. Fittings are not designed to be shortened.

Measure pipe length from end of socket

dBlue® pipes are made with sockets that are not part of the true pipe length. Ensure measurements are made from the end of the socket, which will prevent pipes becoming too short.

Cut pipe square

Cut the pipe square using pipe cutters or a fine toothed hand saw for the best results. Fix the pipe before cutting. A mitre box can be used to assist in obtaining a square angle.

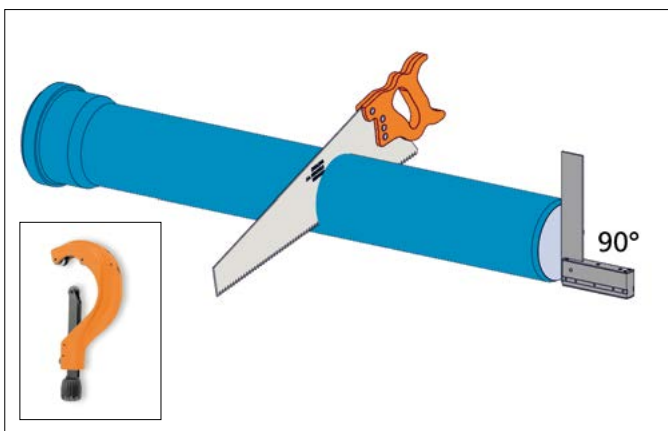

Illustration 6.1

! Do not use high speed electrical cutting tools which will cause heavy burrs and will possibly melt the plastic.

Debur and chamfer pipe

Proper deburring and chamfering of the pipe is required to allow the pipe to be inserted past the rubber ring in the socket.

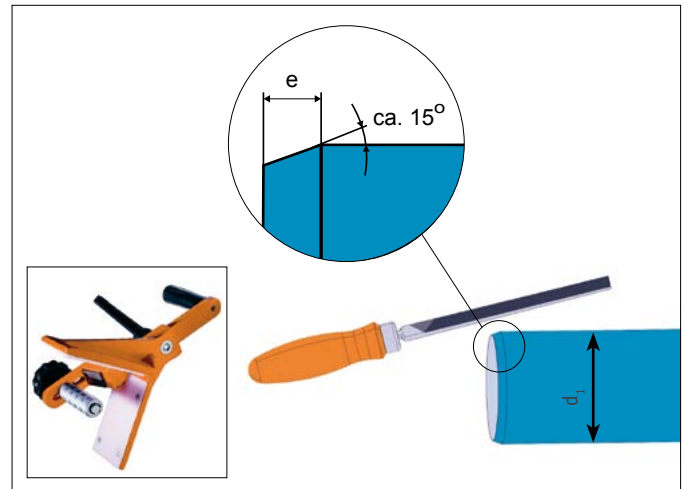

Illustration 6.2

The chamfer angle is always 15°. We recommend the use of a purpose designed chamfering tool for best results. A fine file could also be used but has less precision. Remove any leftover burrs using a standard deburring tool.

The chamfer length e differs per diameter according the table below. Uncut pipes have a chamfer already.

d_1	Chamfer length e (mm)
50	3,5
75	3,5
110	4,5
160	6,0

Table 6.1

Take care when chamfering at low temperatures. Marley dBlue® is able to be installed at temperatures as low as -10°C without becoming brittle.

! Without deburring and chamfering, the pipe spigot end can damage the rubber ring or even separate it from the socket, both resulting in leakage. Burrs along the edge will prevent lubrication to be distributed uniformly over the pipe.

6.2 Jointing pipes and fittings

When making joints the socket of the pipe or fitting should be in a downstream direction for best flow results.

Clean

Clear the rubber ring, the inside of the socket and the product to be inserted from any dust and dirt.

Lubricate

Using dBlue® lubrication. Apply in the ring (and spigot if necessary) do not use too much.

Insert fully

Each joint must initially be made by fully inserting the spigot end into the entire depth of the socket until it stops (1).

Mark spigot end

Clearly mark the spigot end at the inserted depth with a permanent pen. Mark the fitting on a clearly visible side. This will allow visual inspection of each joint after installation (2).

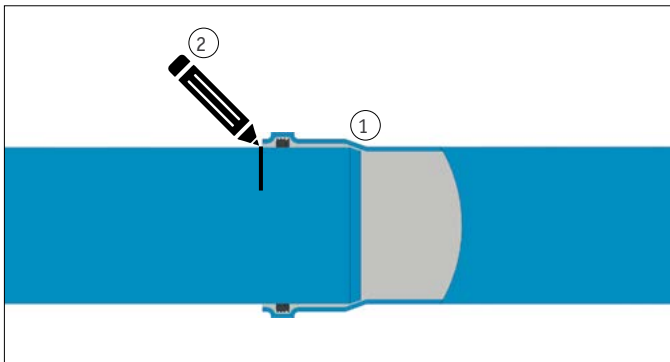

Illustration 6.3

Pull back 10 mm

Pipe that is 500 mm or longer has to be pulled back 10 mm to allow for thermal expansion. Shorter pipes and fittings can remain fully inserted in the socket (3).

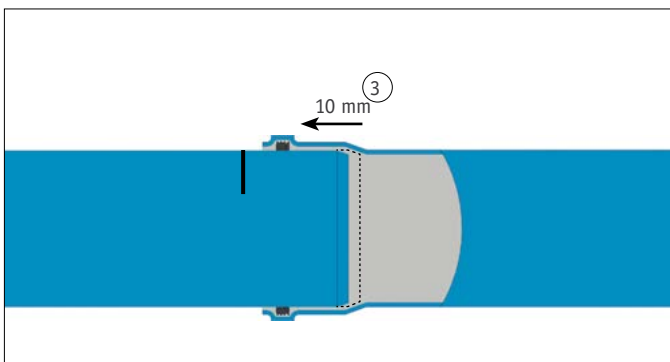

Illustration 6.4

! The dBlue® system uses each socket to compensate for thermal expansion of the pipe system under influence of temperature changes.

Pulling back the spigot end 10 mm from the socket creates enough room to allow for a 3 m pipe to expand and contract.

6.3 Fixing system

This chapter will describe the correct installation of the dBlue® acoustic bracket. The Marley dBlue® bracketing plan requires the use of guide and anchor point brackets.

+ dBlue® uses a single bracket type. The bracket is used as a guide bracket when installed with the supplied spacers and as an anchor point bracket without spacers.

Guide bracket installation

The dBlue® acoustic bracket is designed to function as guide bracket in open position by using two spacers at the bracket closing point.

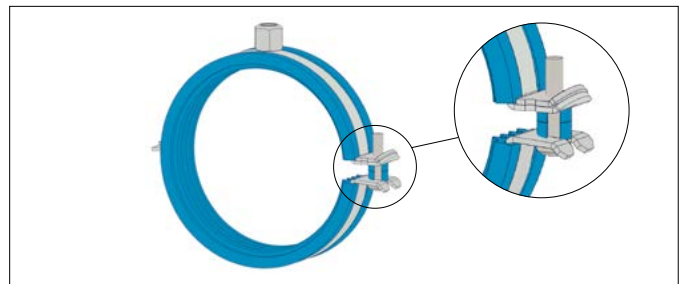

Illustration 6.5

The spacers are pre-installed and can be closed without creating an anchor point.

Anchor point bracket installation

The dBlue® acoustic bracket is designed to function as an anchor point bracket in fully closed position (without spacers).

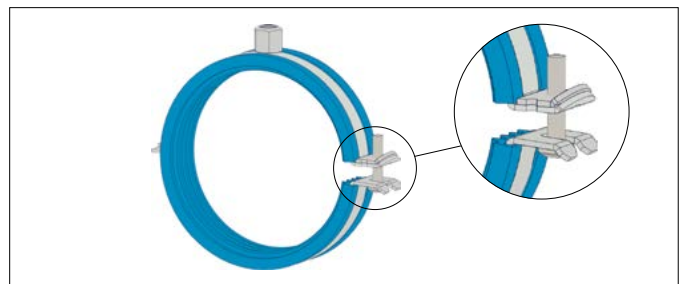

Illustration 6.6

Bracket connection to the wall and ceiling

All dBlue® brackets have a M10 nut for further connection to the wall and ceiling. The suspension should be level and tension free.

Marley dBlue® is a complete system including dBlue® acoustic brackets for optimal sound dampening. The Marley dBlue® fixing system includes:

- Vertical bracketing plan
- Horizontal bracketing plan
- Correct use of guide and anchor point brackets
- Correct tension free installation of each bracket
- Correct installation of each dBlue® joint
- Support bracing

! Follow the design guidelines for the vertical and horizontal bracketing plan, support bracing and correct installation of each dBlue® joint as described elsewhere in this manual.

6.4 Transitions to other materials

6.4.1 PVC system

PVC systems are manufactured according to AS/NZS 1260 and have different pipe sizes from Marley dBlue® below DN110. Connections from PVC systems with non-compatible diameters are possible using PVC adaptor fittings from the Marley dBlue® range.

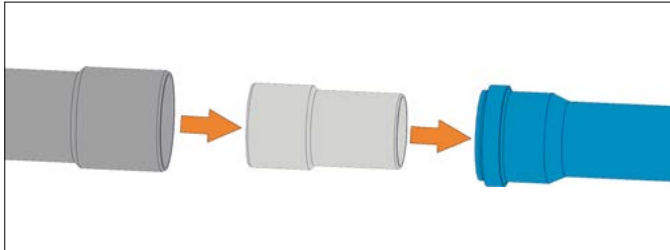

Illustration 6.7

Install the PVC adaptor fittings according to the following instructions:

Clean

Clean the PVC adaptor, the PVC socket as well as the rubber ring inside of the dBlue® socket from any dust and dirt.

Connect PVC side first

Apply primer and solvent cement on the correct part of the adaptor fitting and insert into the female socket of the PVC system.

Connect dBlue® socket next

Apply lubricant to the other side of the PVC adaptor and insert into the dBlue® socket. Where required install the additional reducer first.

! The transition adaptor needs to be pushed in firmly all the way to ensure uninterrupted flow.

For pipe sizes DN110 and DN160 no adaptor fitting is required since both systems have identical outer diameters. Refer to the table below for the possible transitions.

From PVC DN	To dBlue® DN	PVC adaptor OD (mm)	Additional reducer OD (mm)
40	50	43/40	
50	50	56/50	
65	75	69/75	

Table 6.2

6.4.2 Plumbing fixture drainage fittings

Connections from plumbing fixture drainage fittings are typically installed with copper pipe. Copper is manufactured according to AS 1432 and has different pipe sizes than Marley dBlue®. Connections from copper pipe to Marley dBlue® are possible using adaptor fittings with pre-installed rubber nipple.

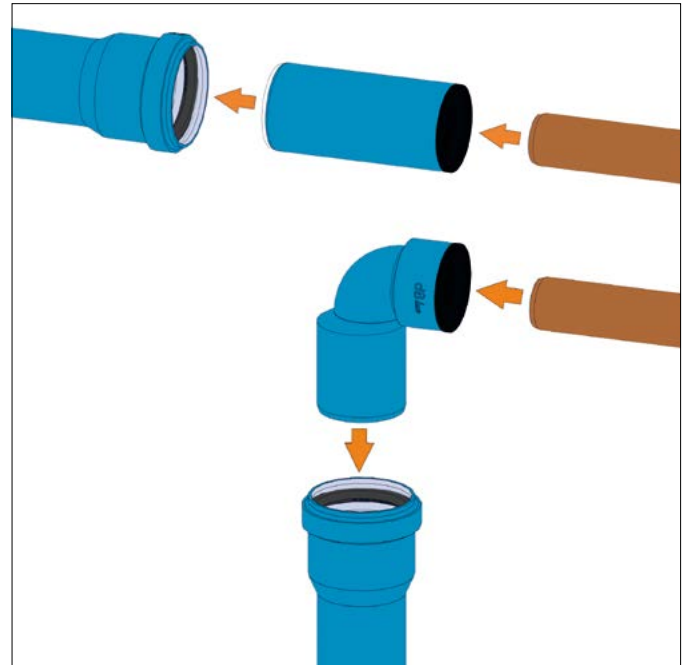

Illustration 6.8

Refer to the table below for the possible transitions available both straight and as a bend.

From copper DN	To dBlue® DN	Rubber nipple/spigot OD (mm)
40	50	38,1/50

Table 6.3

Install the adaptor fittings according to following instructions:

Clean and deburr

Clean the rubber nipple and ensure the plumbing fixture drainage pipe is free from burrs. Use a file to create a slight chamfer for better insertion.

Insert the plumbing fixture drainage pipe

Apply lubricant to the inside of the rubber nipple and outside of the pipe. Fully insert the drainage pipe until it stops. Connect the dBlue® spigot side as a regular dBlue® fitting.

! When adjusting the inserted pipe ensure the rubber nipple stays fully inserted into the socket. Use lubricant to allow good pipe movement.

6.4.3 Cast iron and other materials

For connections from and to cast iron or other drainage pipe materials we advise the use of flexible rubber sleeve adaptors with stainless steel worm-gear clamps.



Illustration 6.9

The rubber sleeve adaptor should have the same temperature and chemical resistance as the Marley dBlue® system. Check the rubber sleeve manufactures guidelines for correct installation and material specifications.

6.5 Floor waste gully

The dBlue® floor waste gully is equipped with:

- 3x closed 50 mm socketed side inlets
- 1x open 110 mm socketed top inlet
- 1x open 75 mm socketed side outlet
- Trap with 75 mm water height

! The snap caps and rubber rings of the 50 mm side inlets must be installed after drilling open the required inlets.

Install the floor gully according to the following steps:

Open the required inlets

Drill a hole through the gully body for the required inlets using a 45 mm hole saw. Temporarily remove the trap from the floor gully preventing unwanted damage.



Illustration 6.10

Insert rubber seals and install snap caps

Insert the rubber seals and install the snap caps to the 50 mm inlets. Any 50 mm inlets that have not been utilized can have their seals and caps installed for potential future use. Re-insert the trap.



Illustration 6.11

Place floor waste gully beneath slab

Insert the top inlet over the 110 mm pipe coming through the slab penetration.

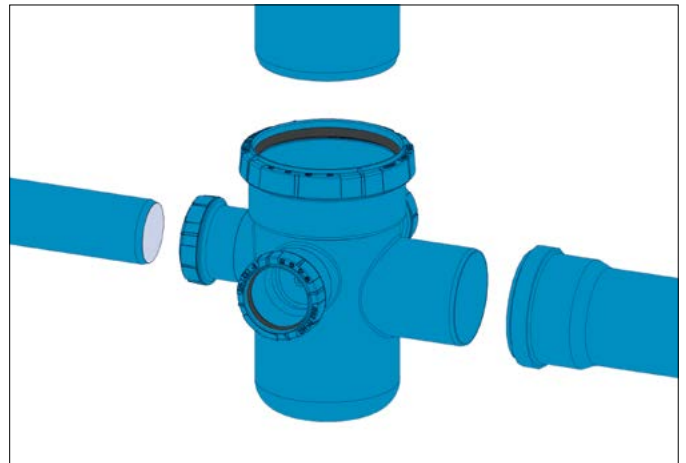

Illustration 6.12

Fixate the floor gully to the slab

Secure the floor gully to the ceiling using anchor point brackets on the 75 mm outlet and opposite 50 mm inlet.

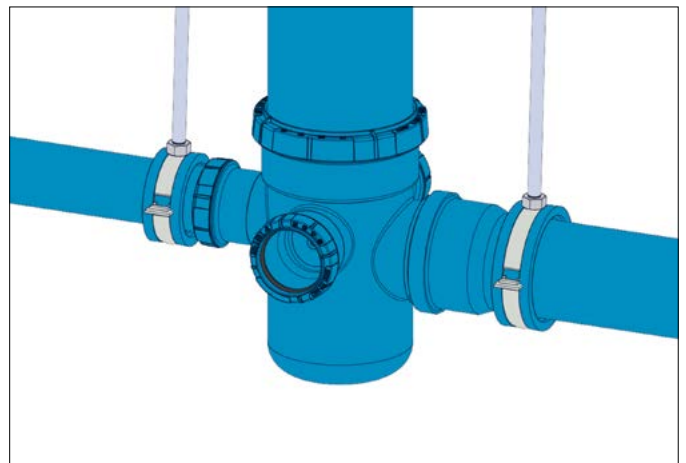

Illustration 6.13

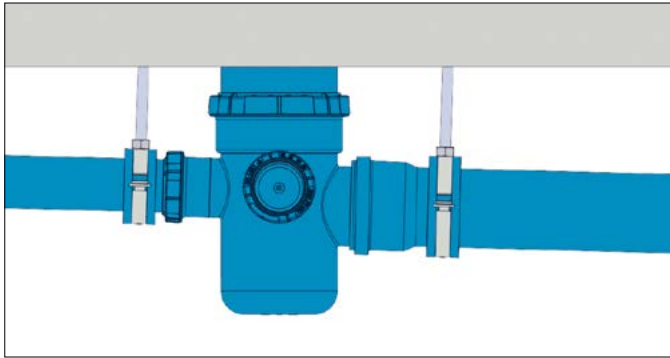

Illustration 6.14

6.6 Shaft inspection

Use the dBlue® inspection piece for shaft inspection. Install according to AS/NZS 3500.2 section 4.4 inspection shaft and boundary traps.

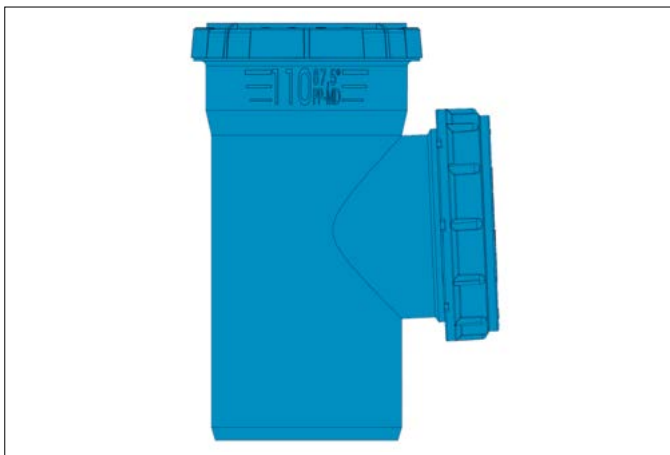

Illustration 6.15

Place the inspection piece according to the standard joint procedure and tighten the screw cap with rubber seal fully after installation.

! Do not use sharp tools for shaft inspection and cleaning.

6.7 Embedding Marley dBlue® in concrete

The Marley dBlue® system is suited to be embedded in concrete. However certain precautions need to be taken during design and installation.

Follow the instructions in the planning and design chapter on:

- Expansion and contraction compensation
- Pressure and heat during pouring
- Acoustic design

When installing Marley dBlue® in concrete always:

- Seal each joint with adhesive strip material before pouring, this will prevent concrete from entering
- Close open pipe sections before pouring
- Secure the pipe system against movement
- Avoid walking on the pipe system
- Avoid placing weight and steel reinforcements directly on the pipe system

! Use extra care when installing dBlue® in concrete because it's difficult to reach after installation.

6.8 Fire protection

Marley dBlue® has fire behaviour class B2 (normally inflammable) according to DIN 4102-1 and class E (normally inflammable) according to EN 13501-1. When dBlue® passes through fire-rated building elements, it is mandatory to install fire protection collars that will not reduce the fire-rating of these building elements.

! Fire collars can be installed casted within the concrete slab or retro-fitted after the slab and pipe are installed.

Fire collars must be installed around the pipe only, not around the socket.

The Marley dBlue® system dimensions can be installed in combination with a range of fire protection collars. The installed system needs to be in accordance with AS 1530.4. Details are available upon request.

We advise to follow the manufacturer's guidelines with respect to design, installation, commissioning and maintenance of the used fire protection collars. Contact the responsible authority for compliance with applicable regulations.

! During design, installation and commissioning of the fire protection collars the applicable on-site, local and national regulations must be observed.

6.9 Using pipe remainders without a socket

Cut pipe without a socket can be used in combination with a double socket. Make sure to follow the debur, chamfer and joint procedure.

Install an anchor point bracket in the middle of each double socket, which will ensure no movement of the fitting.

Allow for sufficient expansion room.

6.10 Additions to an existing system

Modification and additions to existing systems is possible using a sleeve coupler. The sleeve coupler slides over a pipe completely because it has no centre stop.

7 Product range

7.1 Dimensions

The dimensions of the pipe and fittings in the product tables are all in mm unless stated differently. The standard wall thickness of the fittings is not included in the tables, but can be found in the table below.

Diameter d_1	Wall thickness e
50	1,8
75	2,3
110	3,4
160	4,9

Table 7.1

7.2 Abbreviations

Abbreviation	
DN_1	Nominal dimension
d_n / d_1	External dimension fitting/pipe
Z_1	Length until insertion point
α°	Angle of fitting
L	Total length fitting
l_1	Partial length of fitting

Table 7.2

Pipe with socket

PP-MD

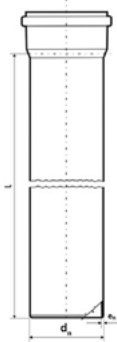

d_n	L	dBlue® code	e
50	150	PA.100.50.0.15	1,8
50	1000	PA.100.50.1.0	1,8
50	3000	PA.100.50.3.0	1,8
75	1000	PA.100.75.1.0	2,3
75	3000	PA.100.75.3.0	2,3
110	150	PA.100.110.0.15	3,4
110	1000	PA.100.110.1.0	3,4
110	3000	PA.100.110.3.0	3,4
160	1000	PA.100.160.1.0	4,9
160	3000	PA.100.160.3.0	4,9

Reducer

PP-MD

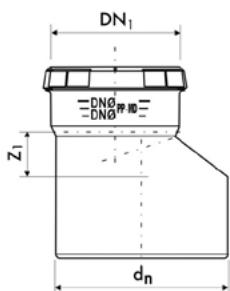

d_n/DN_1	dBlue® code	Z_1
75/50	PA.123.75.50	25
110/50	PA.123.110.50	25
110/75	PA.123.110.75	25

Elbow

PP-MD

15°, 30°, 45°, 67,5°, 87,5°

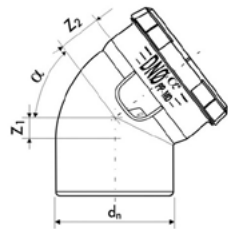

α°	d_n	dBlue® code	Z_1	Z_2
15	50	PA.101.50.15	4	13
15	75	PA.101.75.15	12	16
15	110	PA.101.110.15	14	18
30	50	PA.101.50.30	8	12
30	75	PA.101.75.30	14	15
30	110	PA.101.110.30	20	22
45	50	PA.101.50.45	12	20
45	75	PA.101.75.45	20	28
45	110	PA.101.110.45	25	35
45	160	PA.101.160.45	38	60
87,5	50	PA.101.50.88	33	35
87,5	75	PA.101.75.88	41	49
87,5	110	PA.101.110.88	61	75
87,5	160	PA.101.160.88	99	98

* swept bend

Branch

PP-MD

45°, 67°, 87,5°

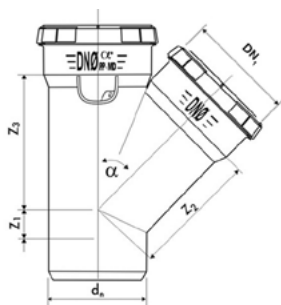

α°	d_n/DN_1	dBlue® code	Z_1	Z_2	Z_3
45	50/50	PA.104.50.45	17	67	67
45	75/50	PA.104.75.50.45	1	83	81
45	75/75	PA.104.75.45	23	96	97
45	110/50	PA.104.110.50.45	13	108	100
45	110/110	PA.104.110.45	29	140	140
87.5	50/50	PA.104.50.88	33	34	35
87.5	75/75	PA.104.75.88	47	50	50
87.5	110/110	PA.104.110.88	62	70	70

Clean out branch

PP-MD

90°



d_n	dBlue® code	Z_1
110	PA.129.110	131

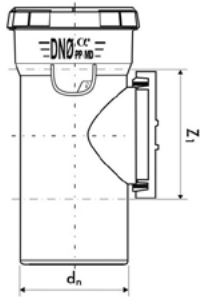

Sleeve socket / Slip coupler

PP-MD



DN_1	dBlue® code	L
50	PA.110.50	97
75	PA.110.75	104
110	PA.110.110	116
160	PA.110.160	140



Double socket / Stop coupler

PP-MD



DN ₁	dBlue® code	L
50	PA.121.50	100
75	PA.121.75	104
110	PA.121.110	116
160	PA.121.160	140



Socket plug

PP-MD



d _n	dBlue® code	L
50	PA.137.50	32
75	PA.137.75	33
110	PA.137.110	37

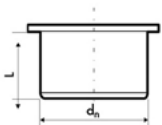

Trap connection socket

PP-MD



d ₁ /d	dBlue® code	L
50/40	PA.110.50.Trap	100

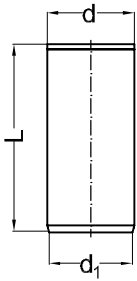

Trap connection bend



d ₁ /d	dBlue® code	l
50 x 40	PA.101.50.88.Trap	80

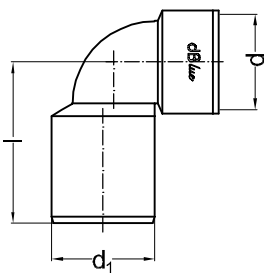

Transition from PVC to dBlue®

PVC



d_1/d_2	dBlue® code	L
43/50	PA.50.40.400	400
56/50	PA.50.50.200	200
69/75	PA.75.65.200	200

Floor waste gully

PP-MD



$d_1/d_2/d_3$	dBlue® code	L	l_1	l_2
110/50/75	PA.159.110.75	210	121	101

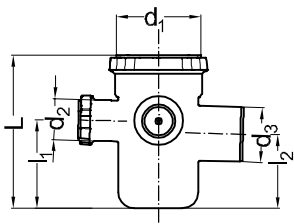

Acoustic bracket

Metal with rubber inlay



DN ₁	dBlue® code
50	PA.140.50M
75	PA.140.75M
110	PA.140.110M

dBlue® uses a single bracket type. The bracket is used as a guide bracket when installed with the 2 supplied spacers and as an anchor point bracket without spacers.

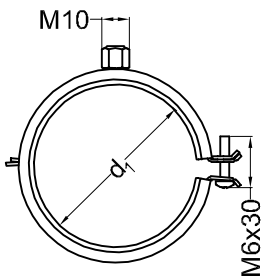

dBlue® lubrication



	dBlue® code
250 ml	DBJL250

8 Approvals, standards and quality

8.1 Approvals

Marley dBlue® has been approved the following certification agencies:

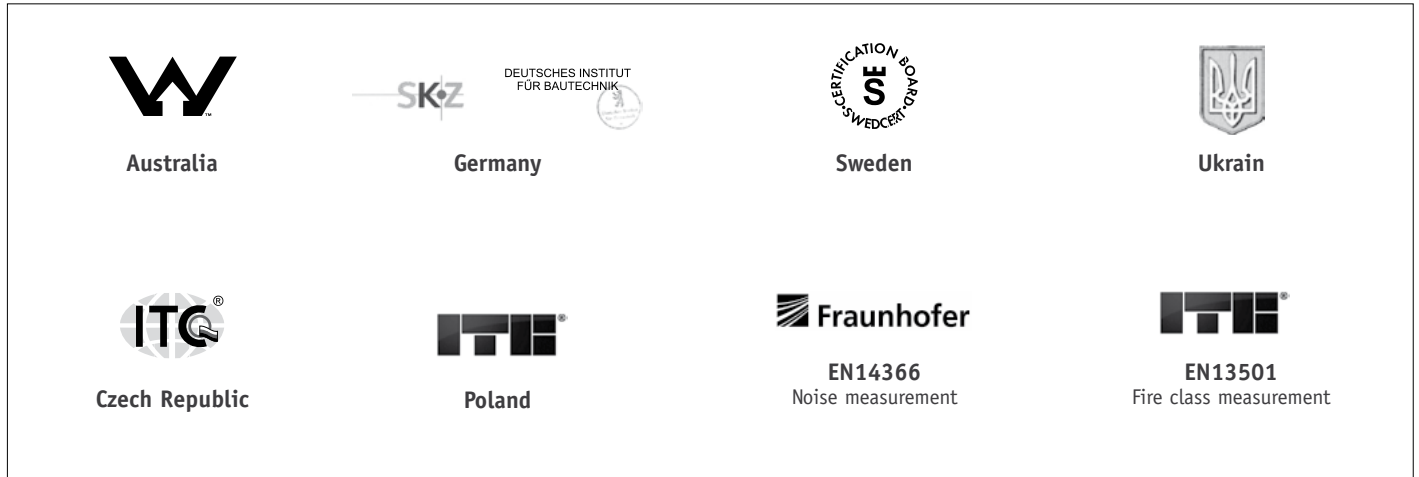

Illustration 8.1

8.2 Standards

Marley dBlue® is a professional acoustic soil & waste drainage system and meets a number of quality and safety standards.

AS/NZS 7671

Plastic piping systems for soil and waste drainage (low and high temperature) inside buildings - Polypropylene (PP).

AS/NZS 5065

Polyethylene and polypropylene pipes and fittings for drainage and sewage applications.

AS 2887

Plastic waste fittings.

AS/NZS 3500.2

Sanitary plumbing and drainage.

AS 1530.4

Method for fire tests on building materials, components and structures.

EN 1451

Plastic piping systems for soil and waste discharge (low and high temperature) within the building structure. Polypropylene (PP). Specifications for pipes, fittings and the system.

EN 1411

Plastic piping and ducting systems. Thermoplastic pipes. Determination of resistance to external blows by the staircase method.

EN 14366

Laboratory measurement of noise from waste water installations.

EN 13501

Fire classification of construction products and building elements.

DIN 4102

Fire behaviour of building materials and building components.

EN 1055

Plastic piping systems. Thermoplastic piping systems for soil and waste discharge inside buildings. Test method for resistance to elevated temperature cycling.

EN 1054

Plastic piping systems. Thermoplastic piping systems for soil and waste discharge. Test method for airtightness of joints.

EN 681

Elastomeric seals. Material requirements for pipe joint seals used in water and drainage applications.

AS/NZS ISO 140.7:2006

Acoustics – Measurement of sound insulation in buildings and of building elements.

AS/NZS ISO 717.1:2004

Acoustics – Rating of sound insulation in buildings and of building elements.

8.3 Quality management

Marley dBlue® is developed and manufactured within an ISO 9001 Quality Assurance system. It emphasises on quality care and continuous improvements for customer satisfaction.

Furthermore Marley has integrated the ISO 14001 environmental management system to control and improve our overall environmental performance.

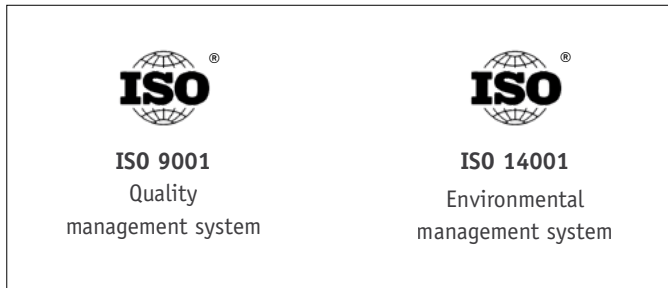

Illustration 8.2

8.4 Warranty

dBlue® guarantees the proper functioning of your drainage system by combining training upfront, technical support during construction and (if required) inspection afterwards.



The dBlue® system comes with a 10 year warranty, details are available on request. Special conditions apply.

8.5 Aliaxis

Marley is a part of Aliaxis, which is the largest producer of plastic pipe systems in the world. The Aliaxis group has 14.000 employees and comprises of more than 100 companies with subsidiaries in 40 countries. All companies operate under their own brand and are specialized in specific solutions for building, industrial and utility applications. Marley is the brand within Aliaxis focusing on specialist drainage systems in the commercial and industrial building sector.

Sustainable Manufacturing

Marley is committed to creating environmentally sustainable processes and products and was the first plastics manufacturer in New Zealand to achieve ISO14001 registration. We are also Best Environmental Practice certified for our entire range of manufactured uPVC systems. This means we get our raw materials from sustainable and responsible sources, continuously work on our manufacturing processes to reduce our environmental footprint and accept our products back at the end of their useful life for recycling.



 FOLLOW US @MARLEYNEWZEALAND

DISCLAIMER

This technical catalogue has been compiled by Marley New Zealand Limited ("The Company") to promote better understanding of the technical aspects of the Company's products to assist users in obtaining from them the best possible performance. The technical catalogue is supplied subject to acknowledgment of the following conditions:

The technical catalogue is protected by Copyright and may not be copied or reproduced in any form or by any means in whole or in part without prior consent in writing by the Company. Product specifications, usage data and advisory information may change from time to time with advances in research and field experience. The Company reserves the right to make such changes at any time without notice. Correct usage of the Company's products involve engineering judgements which cannot be properly made without full knowledge of all the conditions pertaining to each specific installation. The Company expressly disclaims all and any liability to any person whether supplied with this publication or not in respect of anything and of the consequences of anything done or omitted to be done by any such person in reliance whether whole or partial upon the whole or any part of the contents of this publication. No offer to trade, nor any conditions of trading, are expressed or implied by the issue or content of this manual. Nothing herein shall override the Company's Conditions of Sale, which may be obtained from the Registered Office or any Sales Office of the Company. This technical catalogue is and shall remain the property of the Company, and shall be surrendered on demand to the Company. Actual colours may vary slightly from those shown. For a more accurate colour comparison, please request a product sample.

MAR645 October 2021

OUR PARTNERS



REGISTERED MASTER BUILDERS
**ASSOCIATE
MEMBER**



For more information: **0800 MARLEY (0800 627539)** | www.marley.co.nz

 **MARLEY**
by **alixis**